



General

- Fast Acting
- 1.6mm×0.8mm physical size
- Thick film manufacturing method, ceramic substrate, silver fusing element
- -50°C~125°C operating temperature
- Excellent environmental integrity
- RoHS compliant
- Halogen-free

Agency / Certificate Information

Agency	File Number	Ampere Range
	JDYX2.E319512	1A~6A
	JDYX8.E319512	1A~6A

Application

- Battery pack
- PC related equipment and peripherals (Hard driver, Printer, etc.)
- Portable devices (Mobile phone, PDA battery charger, etc.)
- Digital camera (Digital still camera)
- Game equipment
- LCD monitor, LCD modules
- Wireless base station

Ordering Information

Part Number	Marking	Current Rating (A)	Voltage Rating	Interrupting Rating	Max Cold DCR*(Ω)	Typical I ² T** (A ² S)
S0603-F-1.0A	H	1.0	32V DC	50A/32V DC	0.252	0.0150
S0603-F-1.5A	K	1.5			0.108	0.0365
S0603-F-2.0A	N	2.0			0.058	0.0595
S0603-F-2.5A	O	2.5			0.043	0.1222
S0603-F-3.0A	P	3.0			0.044	0.1350
S0603-F-3.5A	R	3.5			0.032	0.1891
S0603-F-4.0A	S	4.0	32V DC	35A/32V DC	0.019	0.3559
S0603-F-5.0A	T	5.0			0.0135	0.7030
S0603-F-6.0A	6	6.0			0.0115	0.8861

* Measured at ≤10% rated current and 25°C

** Melting I²T at 10 times of rated current

Catalog Symbol

S 0603-F-1.0A

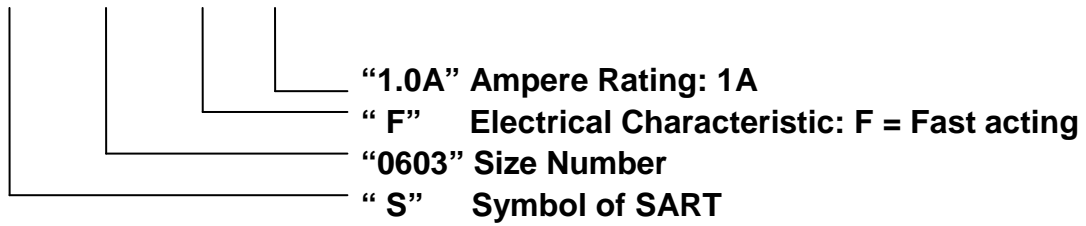

Dimensions

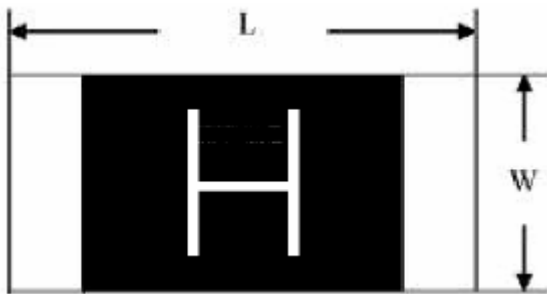

L(mm)	W(mm)	T(mm)	B(mm)
1.60±0.15	0.80±0.15	0.40±0.10	0.30±0.20



Recommended Land Patterns

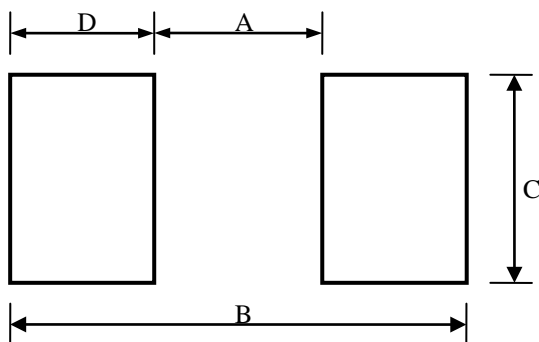

Materials

Components	Material
Substrate	Ceramic
Terminations	Silver over-plated with tin (100%)
Element	Silver or Silver / Palladium

Dimensions	A(mm)	B(mm)	C(mmm)	D(mm)
Spec	1.00±0.20	3.00±0.50	1.40±0.20	1.00±0.30

Time Current Curve

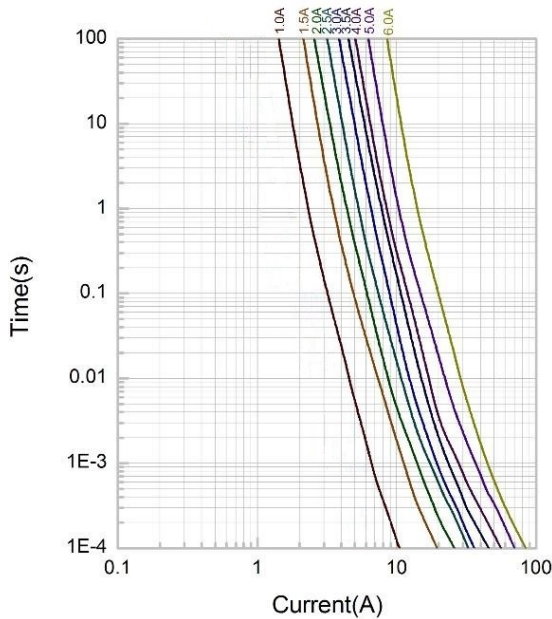

I²T vs Time Curve

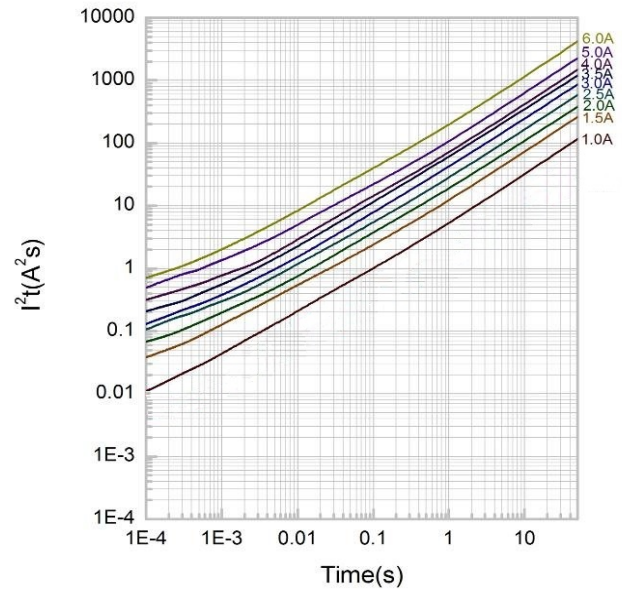

Electrical Characteristics

Ampere Rating	% of Current Rating	Opening Time
1A-6A	100%	> 4 hours
1A-6A	250%	≤ 5 sec

Temperature Derating Curve

- The current carrying capacity will be affected by ambient temperature which was showed in the figure.
- This current derating curve is for fusing characteristics.

Example,

Work Temp:80°C,

Temp derating factor = 91%

$I_{actual} = I_{normal} / 0.91$

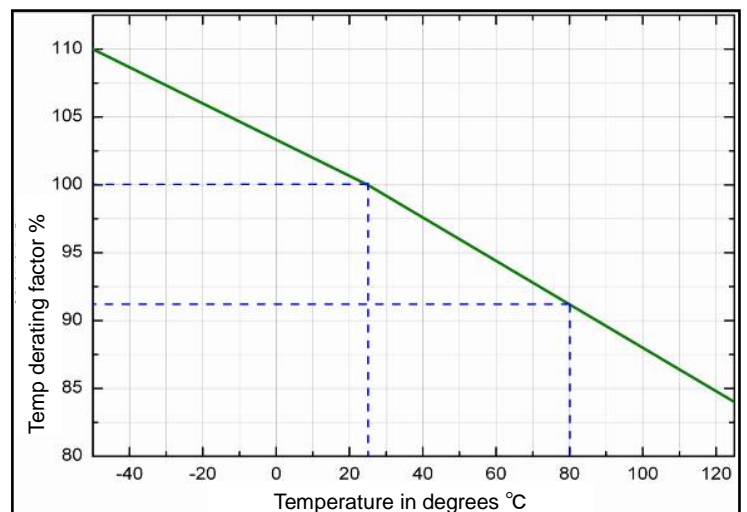

Reliability Test

Item	Test condition / Methods	Performance	Standard
Voltage Drop	100% In; Temperature in fuse was stabilized	Deviation between the mean value:<15%	IEC 60127-1
Time/Current	100% In	No Fusing;4hours Min.	Refer to SART Spec
	250% In	Within 5sec	
Endurance Test	100% In, 1h on,15min off, 100 cycles; followed by 1h at 125%In	$ \Delta R < 10\%$ Legible appearance	IEC 60127-1
Maximum Sustained Dissipation	125%In, during the last 10min of the endurance test	changed with current rating	IEC 60127-1
Temperature Rise	100%In	$ \Delta T < 75^\circ\text{C}$	UL248-14
Interrupting Ability	50A /32V DC(1A-3.5A) 35A/32V DC(4A-6A)	Without permanent arcing, ignition and bursting of fuse link	UL248-14
Solderability	$240^\circ\text{C} \pm 5^\circ\text{C}$, 3sec $\pm 0.5\text{sec}$	95% coverage Min.	IEC60127-4 IEC60068-2-20 MIL-STD-202
Resistance to Soldering	$260^\circ\text{C} \pm 5^\circ\text{C}$, 10sec $\pm 0.5\text{sec}$	$ \Delta R < 10\%$ Legible appearance	MIL-STD-202 IEC60127-4
Bending Test	Distance between holding points: 90mm Bending: 1mm ; time:10sec	$ \Delta R < 10\%$ No mechanical damages	IEC 60127-4
High Temperature Operating Life	$70^\circ\text{C} \pm 2^\circ\text{C}$, 96hours, at 60% In	$ \Delta R < 10\%$; no fusing	MIL-STD-202 Method 108
Low Temperature Storage	$-55^\circ\text{C} \pm 2^\circ\text{C}$, 96hours	$ \Delta R < 10\%$	IEC60068-2-1
High Temperature Storage	$125^\circ\text{C} \pm 2^\circ\text{C}$, 96hours	$ \Delta R < 10\%$	IEC60068-2-2
Humidity (steady state)	$40^\circ\text{C} \pm 2^\circ\text{C}$, 90%~95%RH, 1000hours	$ \Delta R < 10\%$	MIL-STD-202 Method 103
Salt Spray	5% salt solution, 48hours exposure	$ \Delta R < 10\%$ Legible appearance	MIL-STD-202 Method 101
Thermal Shock	5 cycles between $-55^\circ\text{C}/+125^\circ\text{C}$, 60 minutes ; each extreme	$ \Delta R < 10\%$ No mechanical damages	IEC 60068-2-14

Recommended Solder Curve

1.Infrared Reflow:

Temperature : 260°C

Time : 5sec Max.

Recommend Reflow profile

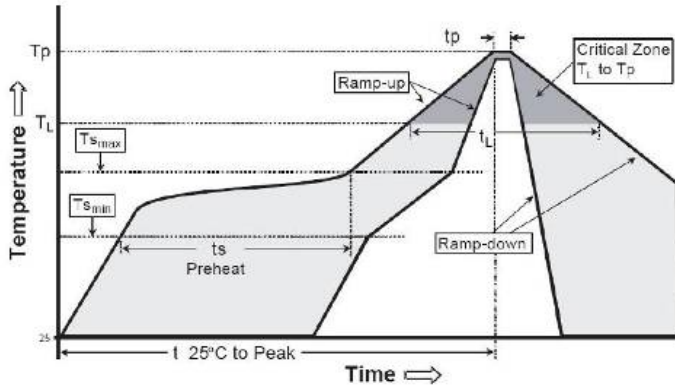

Profile Feature	Pb-Free Assembly
Average Ramp-Up Rate($T_{s\ max}$ to T_p)	3°C/s Max.
Preheat Temperature Min($T_{s\ min}$) Temperature Max($T_{s\ max}$) Time($T_{s\ min}$ to $T_{s\ max}$)	150°C 200°C 60sec~120sec
Peak Temperature(T_p)	260°C
Time within 5°C of actual Peak Temperature(T_p)	5sec
Melting tin time(t_L)	20sec~30sec
Ramp-Down Rate	6°C/s Max.
Time 25°C to Peak Temperature	8 minutes Max.

2.Wave soldering

Reservoir Temperature : 260°C

Time in Reservoir : 10sec Max.

3.Hand Soldering

Temperature : 350°C

Time : 5sec Max.

Packaging

5,000 pieces of fuses in paper taper and reeled on a 178mm(7 inch) reel

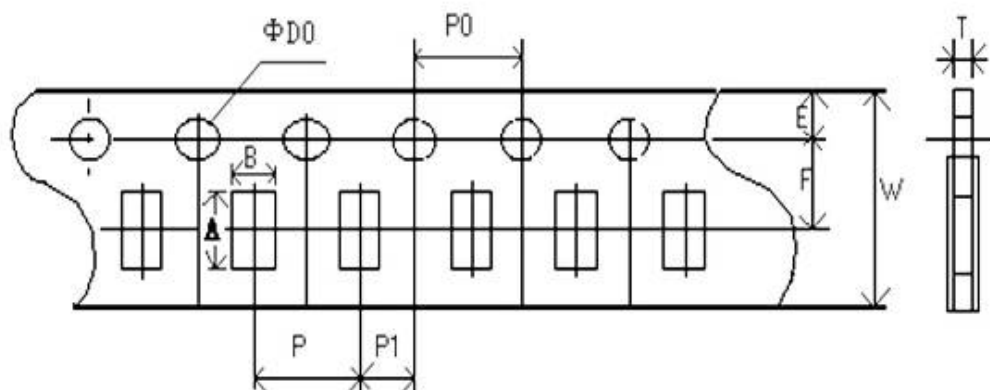

Type	A(mm)	B(mm)	W(mm)	F(mm)	E(mm)
Spec	1.85±0.10	1.10±0.10	8.00±0.20	3.50±0.05	1.75±0.10
Type	P(mm)	P0(mm)	P1(mm)	D0(mm)	T(mm)
Spec	4.00±0.10	4.00±0.10	2.00±0.05	1.50±0.10	0.60±0.10

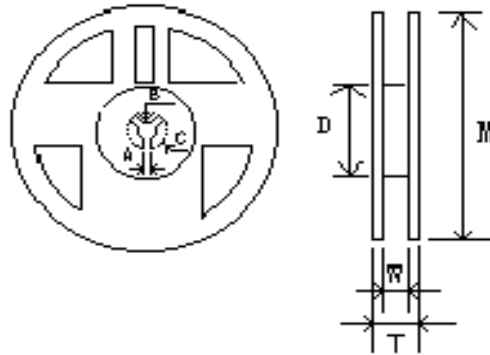

Type	M(mm)	W(mm)	T(mm)	A(mm)	B(mm)	C(mm)	D(mm)
Spec	178.00±2.00	9.50±1.00	12.50±1.50	2.00±0.50	13.00±0.50	21.00±0.50	58.00±2.00

Storage

- The ambient temperature shall between 5°C~30°C.
- The relative humidity recommended for storage is between 25%~60%.
- Sealed plastic bags with desiccant shall be used to reduce the oxidation of the termination and shall only be opened prior to use. The products shall not be stored in areas where harmful gases containing sulfur or chlorine are present.