



General

- Surface mount high current fuse
- Available in ratings of 20 to 60 Amperes
- Higher voltage rating up to 100VDC
- 10.25x3.20 (mm) square shape surface mount
- Operating temperature range from -55°C to 125°C
- Enhanced thermal cycling endurance
- RoHS compliant and Halogen Free

Application

- Storage system power
- Cooling fan system for PC server
- Voltage regulator module
- Base station power supply
- Voltage regulator module for PC server
- High end servers / Blade computing
- Battery Management System

Agency	File Number	Ampere Range
	JDYX2.E319512	20A-60A
	JDYX8.E319512	

Ordering Information

PartNumber	Current Rating (A)	Voltage Rating (VDC)	Interrupting Rating	Typical Cold DCR* (m Ω)	Nominal I ² T** (A ² s)
S1032-F-20A	20	100	100VDC 300A 72VDC 500A 32VDC 1000A	3.08	264
S1032-F-25A	25	100		2.15	413
S1032-F-30A	30	100		2.08	594
S1032-F-40A	40	72	72VDC 180A 60VDC 600A	1.23	1024
S1032-F-50A	50	72		1.00	1650
S1032-F-60A	60	72		0.88	2376

* Measured at ≤10% rated current and 25°C

** Melting I²T at 10 times of rated current



Catalog Symbol

S 1032-F-40A

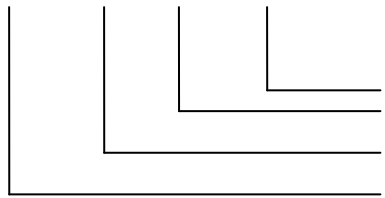

“40A” Ampere Rating: 40A

“F” Electrical Characteristic: F=Fast Acting

“1032” Size Number, 10.25mm*3.20mm*3.20mm

“S” Symbol of SART

Dimensions

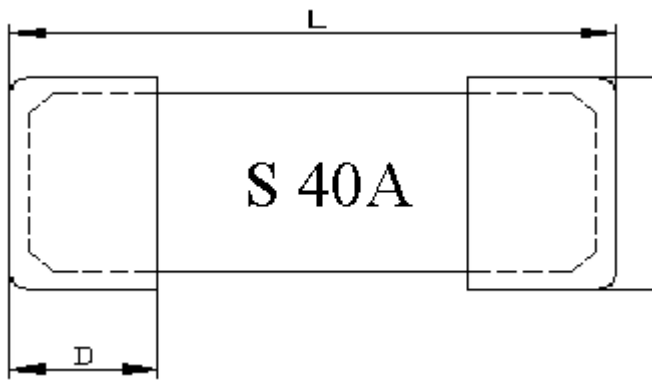

L (mm)	W (mm)	T(mm)	D (mm)
10.25±0.20	3.20±0.15	3.20±0.15	1.75±0.15

Recommended Land Patterns

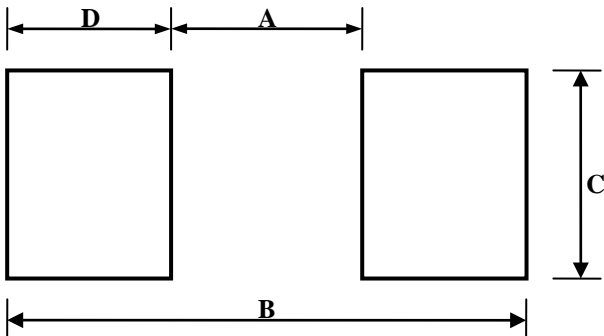

Dimensions	A(mm)	B (mm)	C(mm)	D(mm)
Spec	5.72±0.3	12.6±0.3	3.43±0.3	3.25±0.3

Standard Test Board

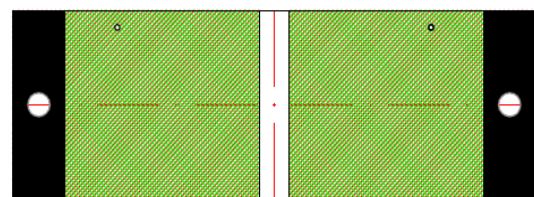
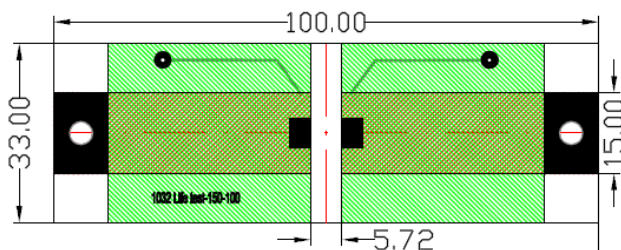

Glass epoxy body on double side;

Board thickness: 1.6mm;

Thickness of Copper layer: ≥100µm;

Width of Copper trace: One side 15mm and the other side 33mm



Electrical Characteristics

Ampere Rating	% of Current Rating	Opening Time
20A-60A	100%	Min.4hr.
20A-60A	200%	Max.60s
20A-60A	1000%	>1ms

Materials

Components	Material
Body	Ceramic
Terminations	Au Plated Brass Cap
Element	Tin Plated Copper

Time Current Curve

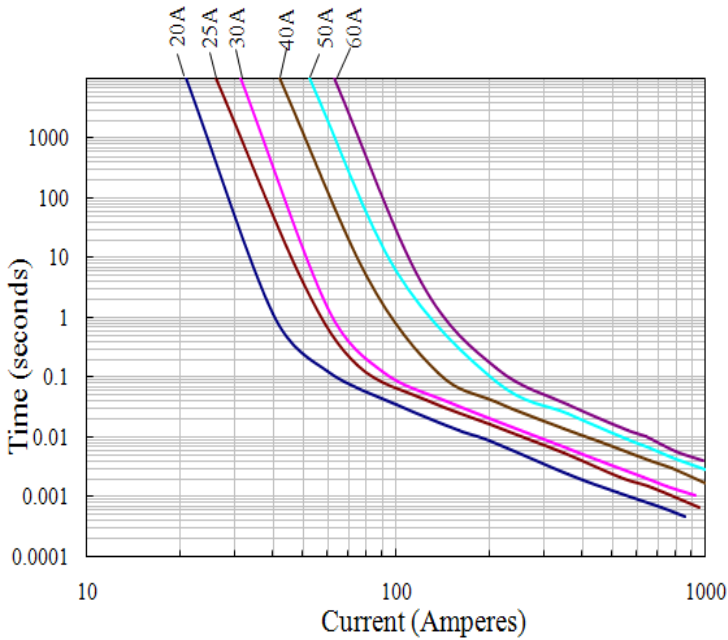

I²T vs Time Curve

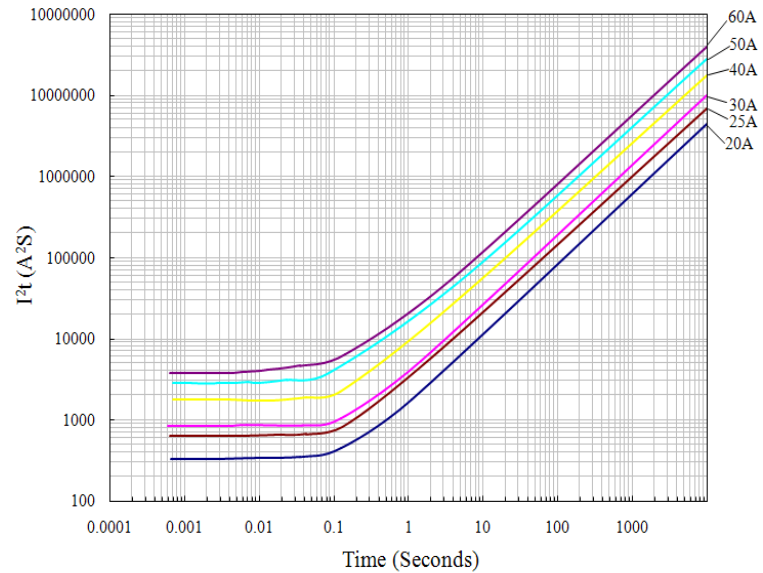

Temperature Derating Curve

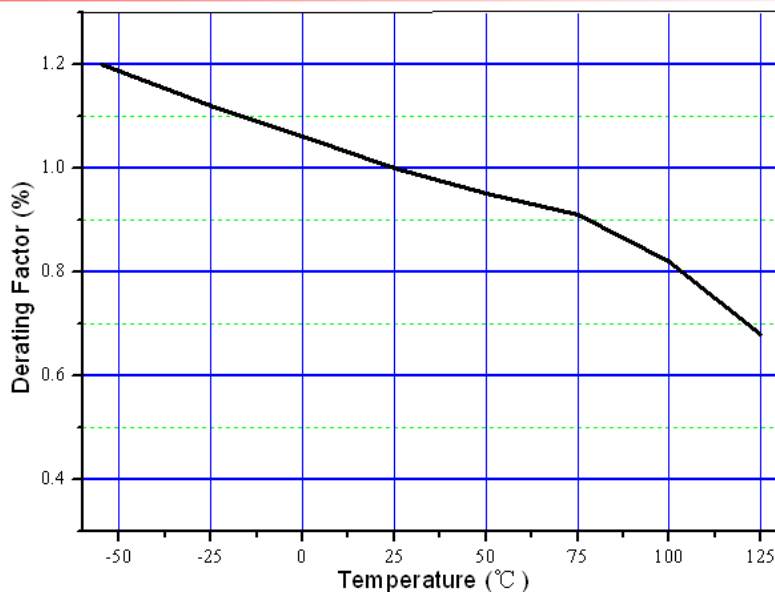

**Reliability Test**

Item	Test condition/ Methods		Performance	Standard
Time/Current	100% In		No Fusing ; 4hr min	UL248-14
	200% In		60s Max.	Refer to SART File
	1000% In		>1ms	Refer to SART File
Endurance Test	100%In for 4hr and testing Temperature rise at the last 5 min.		No fusing; 20A~40A: <90℃ 50A~60A: <105℃	IEC-60127-4
Interrupting Ability	20A-30A	100VDC 300A 72VDC 500A 32VDC 1000A	without permanent arcing, ignition and bursting of fuse link	UL248-14 IEC60127-4
	40A-60A	72VDC 180A 60VDC 600A		
Solderability	240℃±5℃,3s±0.5s		95% coverage min.	IEC60127-4 IEC60068-2-20; MIL-STD-202
Resistance to soldering	260℃±5℃, 10s±0.5s		No Breaking	MIL-STD-202 Method 210
Moisture resistance	TemperatureHumidityDuration: 85±3℃: 85±5%RH: 1000h		ΔR : <10% No mechanical damage	MIL-STD-202 Method 106
Low Temperature Storage	T=-55℃±3℃, 1000h		ΔR : <10%	IEC60068-2-1
High Temperature Storage	T=125℃±2℃, 1000h		ΔR : <10%	IEC60068-2-2
Salt Spray	5%±1%salt solution , 48 h		ΔR : <10%	MIL-STD-202 Method 101
Thermal Shock	100 cycles between -55℃/+125℃, 60 minutes ; each extreme		ΔR : <10%	IEC 60068-2-14
Vibration	Amplitude 10-55 Hz in 1 min. 2 hrs. each XYZ = 6hrs (10-55 Hz)		ΔR : <10% No mechanical damage	MIL-STD-202F Method 201
Mechanical shock	100G's peak amplitude, saw tooth wave 6ms duration, 3 cycles XYZ+ xyz = 18		ΔR : <10% No mechanical damage	MIL-STD-202 Method 213



Recommended Solder Curve

- Infrared Reflow:**
Temperature : 260°C
Time : 5s max.
Recommend Reflow profile

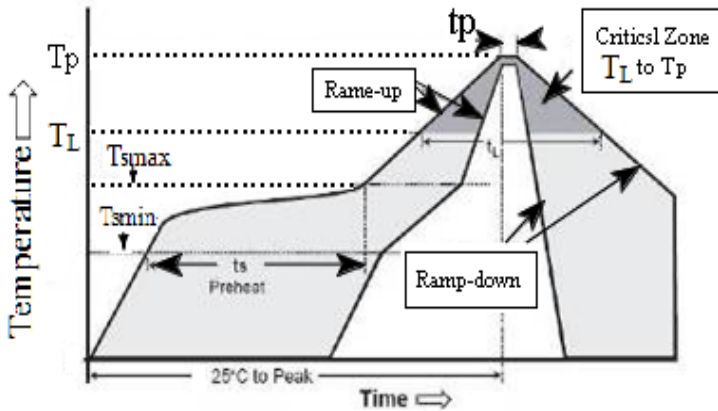

Profile Feature	Pb-Free Assembly
Average Ramp-Up Rate($T_{s_{max}}$ to T_p)	3°C/s max.
Preheat Temperature Min($T_{s_{min}}$)	150°C
Preheat Temperature Max($T_{s_{max}}$)	200°C
Preheat Time($T_{s_{min}}$ to $T_{s_{max}}$)	60s -120s
Peak Temperature(T_p)	260°C
Time within 5°C of actual Peak Temperature(T_p)	5s
Melting tin time(T_L)	20s ~40s
Ramp-Down Rate	6°C/s max.
Time 25°C to Peak Temperature	8 minutes max.

- Wave soldering**
Reservoir Temperature : 260°C
Time in Reservoir : 10s max.

- Hand Soldering**
Temperature : 350°C
Time : 3s max.
Avoid Soldering iron touch with Brass Cap.

Packaging

2000 pieces of fuses on 24mm tape-and-reel on 13 inch (330mm) reel

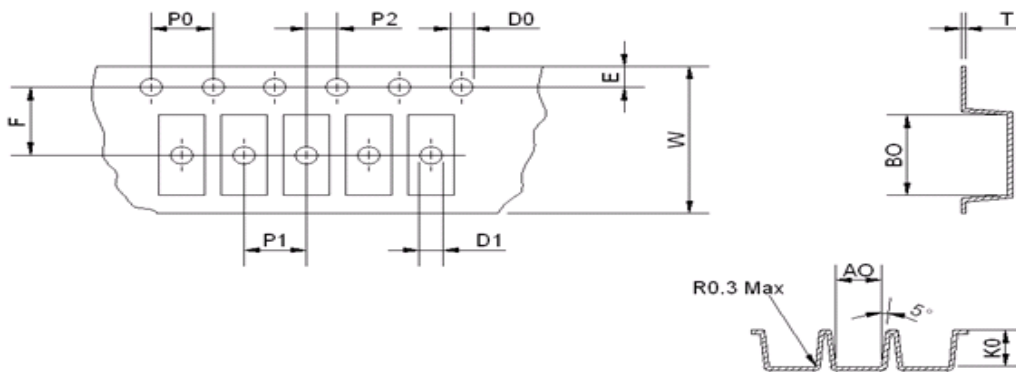

Symbol	A0(mm)	B0(mm)	E(mm)	F(mm)	W(mm)	K0(mm)
Spec.	3.50±0.10	10.60±0.15	1.75±0.10	11.50±0.10	24.00±0.30	3.50±0.10
Symbol	P0(mm)	P1(mm)	P2(mm)	D0(mm)	D1(mm)	T(mm)
Spec.	4.00±0.10	8.00±0.10	2.00±0.10	1.50+0.10/-0	1.50+0.10/-0	0.35±0.05

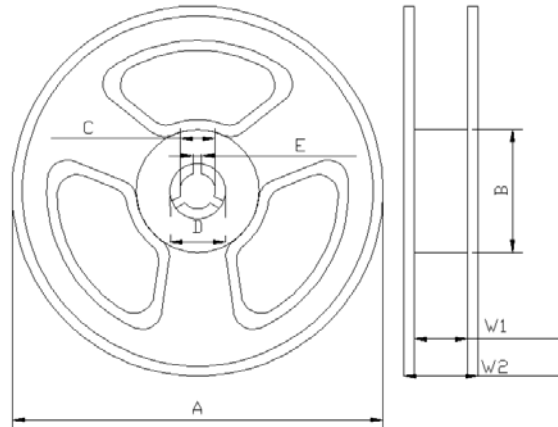

Type	A(mm)	B(mm)	C(mm)	D(mm)	E(mm)	W1(mm)	W2(mm)
Spec	330.0±2.0	100.0±1.5	13.0±0.5	21.0±0.5	2.2±0.2	24.5±1.5	28.5±2.0

Storage

- The ambient temperature shall be kept between 5°C~30°C.
- The relative humidity recommended for storage is between 25%~60%.
- Sealed plastic bags with desiccant shall be used to reduce the oxidation of the termination and shall only be opened prior to use. The products shall not be stored in areas where harmful gases containing sulfur or chlorine are present.