



General

- Fast acting
- 1.6mm× 0.8mm physical size
- Thick film manufacturing method, ceramic substrate, silver fusing element
- -55°C~125°C operating temperature
- Excellent environmental integrity
- RoHS compliant
- Halogen-free
- Lead free

Agency / Certificate Information

Agency	File Number	Ampere Range
	E319512	0.5A~6A

Application

- Battery pack
- PC related equipment and peripherals (Hard driver, Printer, etc.)
- Digital camera (Digital still camera)
- Game equipment
- LCD monitor, LCD modules
- Wireless base station
- Power supply
- Medical device

Electrical Specifications

Part Number	Marking	Current Rating (A)	Voltage Rating (V)	Interrupting Rating (V)	Typical Cold DCR* (mΩ)	Typical I ² T** (A ² sec)
S0603-F-0.5A	F	0.5	32	50A 32V DC	785	0.0074
S0603-F-0.75A	G	0.75	32		450	0.0251
S0603-F-1.0A	H	1.0	32		210	0.0230
S0603-F-1.5A	K	1.5	32		85	0.0473
S0603-F-2.0A	N	2.0	32		47	0.0824
S0603-F-2.5A	O	2.5	32		30	0.1313
S0603-F-3.0A	P	3.0	32		25	0.1890
S0603-F-3.5A	R	3.5	32		21.5	0.2511
S0603-F-4.0A	S	4.0	32	35A 32V DC	16.0	0.3559
S0603-F-5.0A	T	5.0	32		10.7	0.7030
S0603-F-6.0A	6	6.0	32		9.5	1.5120

* Measured at ≤10% rated current and 25°C

** Melting I²T at 10 times of rated current

Part Number Information

S 0603 - F - 1.0A

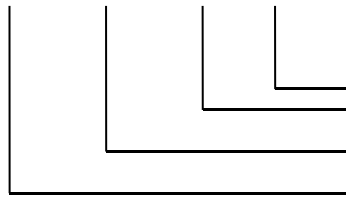

- "1.0A" Ampere Rating: 1A
- "F" Electrical Characteristic: F = Fast acting
- "0603" Size Number
- "S" Symbol of SART

Dimensions

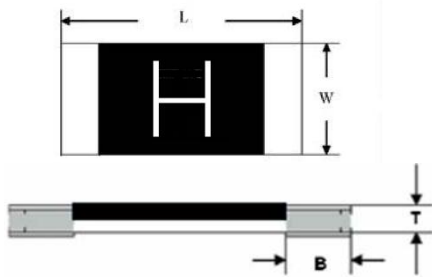

Type	L (mm)	W (mm)	T (mm)	B (mm)
S0603-F	1.60±0.15	0.80±0.15	0.40±0.10	0.30±0.20

Recommended Land Patterns

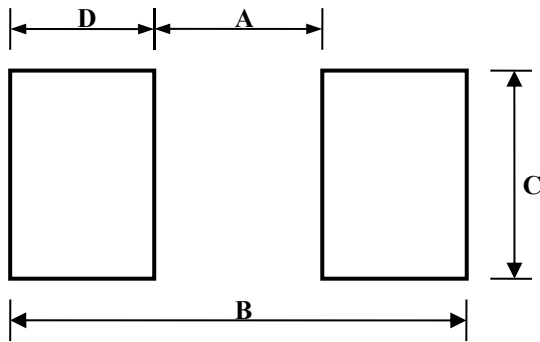

Type	A(mm)	B(mm)	C(mm)	D(mm)
S0603-F	0.85±0.05	2.05±0.050	1.20±0.10	0.60±0.10

Materials

Components	Material
Body	Ceramic
Terminations	Silver over plated with tin (100%)
Element	Silver or Silver/Palladium

Dimensions of Standard Test Board

Type	Ampere Rating	Board Thickness (mm)	Copper Layer Thickness (mm)	Copper Trace Width (mm)
S0603-F	0.5A~6.0A	1.6	0.035	5.0

Time Current Curve

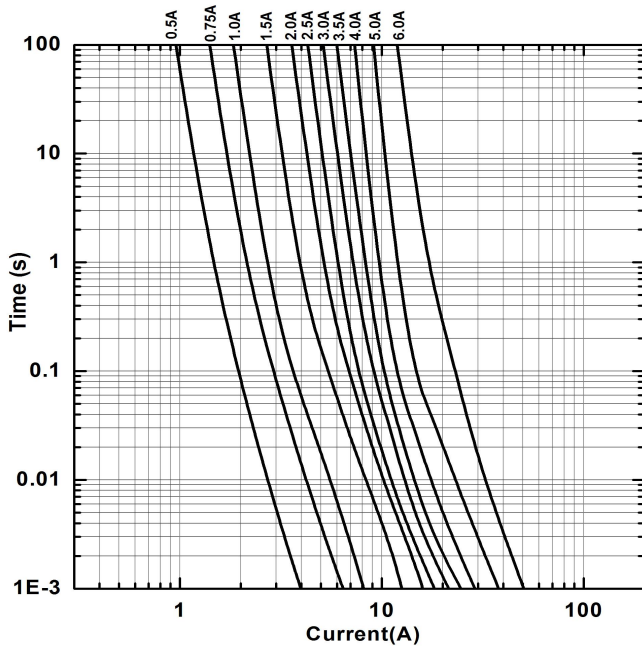

I²T VS Time Curve

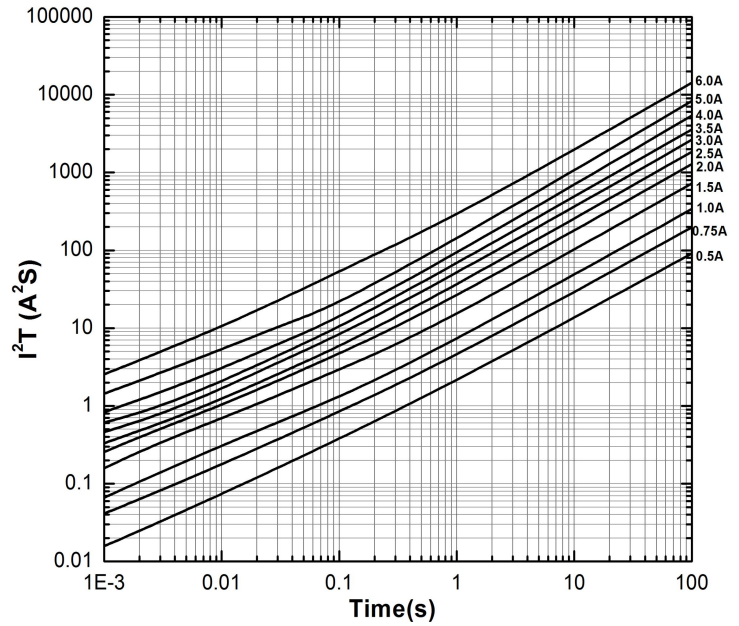

Electrical Characteristics

Type	Ampere Rating	% of Current Rating	Opening Time
S0603-F	0.5A~6.0A	100	4hours Min.
	0.5A~0.75A	250	20sec Max.
	1.0A~6.0A	250	5sec Max.
	0.5A~6.0A	1000	0.1ms Min.

Temperature Derating Curve

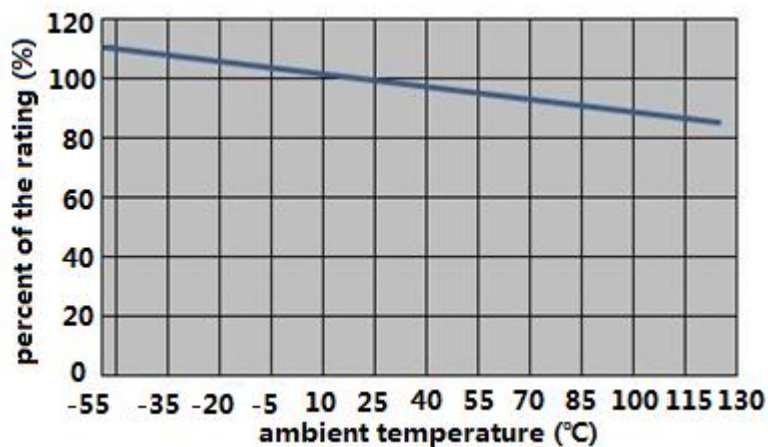

Product Characteristics

Item	Test condition/ Methods	Performance	Standard
Time/Current	100% of current rating	No Fusing, 4hours Min.	UL248-14
	250% of current rating	0.5A~0.75A: ≤20sec 1.0A~6.0A: ≤5sec	SART SPEC.
	1000% of current rating	>0.1ms	
Voltage Drop	100% of current rating	Deviation between the mean value: <15% 0.5A<700mV 0.75A<450mV 1.0~6A<300mV	IEC60127-4
Temperature Rise	100% of current rating	ΔT<75℃	UL248-14
Endurance Test	100 cycles of 1In for 1h "ON", for 15min "OFF", then following by 1h at 125%In	ΔR :<10%	IEC60127-4
Interrupting Ability	0.5A~3.5A: 50A 32V DC 4.0A~6.0A: 35A 32V DC	without permanent arcing, ignition and bursting of fuse link	UL248-14 IEC60127-4
Solderability	240℃±5℃, 3sec±0.5sec	95% coverage Min.	IEC60127-4 MIL-STD-202 Method 208
Resistance to Soldering	260℃±5℃, 10sec±0.5sec	ΔR :<10% Legible appearance	MIL-STD-202 Method 210
Bending Test	Distance between holding points: 90mm Bending: 1mm, time: 10s	ΔR :<10% No mechanical damages	IEC60127-4
High Temperature Operating Life	T=70℃±2℃, 60%In, 96hours	ΔR : <10%; No fusing	MIL-STD-202 Method 108
Humidity (Steady State)	T=40℃±2℃, 90%~95%RH, 1000hours	ΔR : <10%	MIL-STD-202 Method 103
Low Temperature Storage	T=-55℃±3℃, 96hours	ΔR : <10%	IEC60068-2-1
High Temperature Storage	T=125℃±2℃, 96hours	ΔR : <10%	IEC60068-2-2
Salt Spray	5% salt solution, 48hours	ΔR : <10% Legible appearance	MIL-STD-202 Method 101
Thermal Shock	100 cycles between -65℃/+125℃ 60 minutes, each extreme	ΔR : <10% No mechanical damages	MIL-STD-202 Method 107

Recommended Solder Curve

- Temperature: 260°C
- Time: 20sec Max.
- Recommend Reflow profile

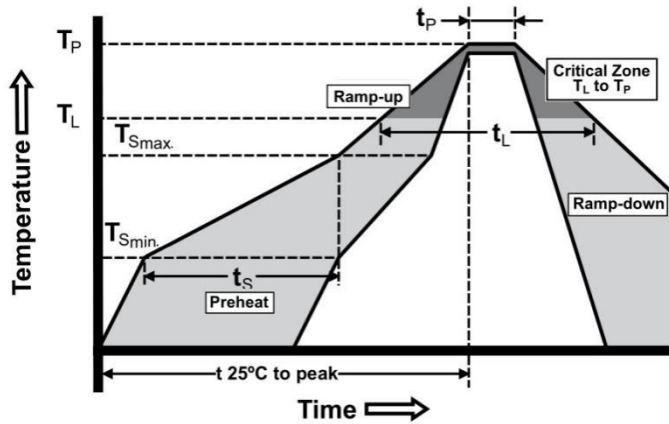

Profile Feature	Pb-Free Assembly
Average Ramp-up Rate(T_{smax} to T_p)	3°C/sec Max.
Preheat Temperature Min. (T_{smin}) Temperature Max. (T_{smax}) Time (t_{smin} to t_{smax})	150°C 200°C 60sec~120sec
Peak Temperature(T_p)	260°C
Time within 5°C of actual Peak Temperature(t_p)	20sec
Melting tin time(t_L)	60sec~150sec
Ramp-down Rate	6°C/sec Max.
Time 25°C to peak Temperature	8minutes Max.

2. Wave soldering

- Reservoir Temperature: 260°C
- Time in Reservoir: 10secMax.

3. Hand Soldering

- Temperature: 350°C
- Time: 5secMax.

Packaging

- 5000 pieces of fuses in emboss taper and reeled on a 178mm(7 inch) reel.

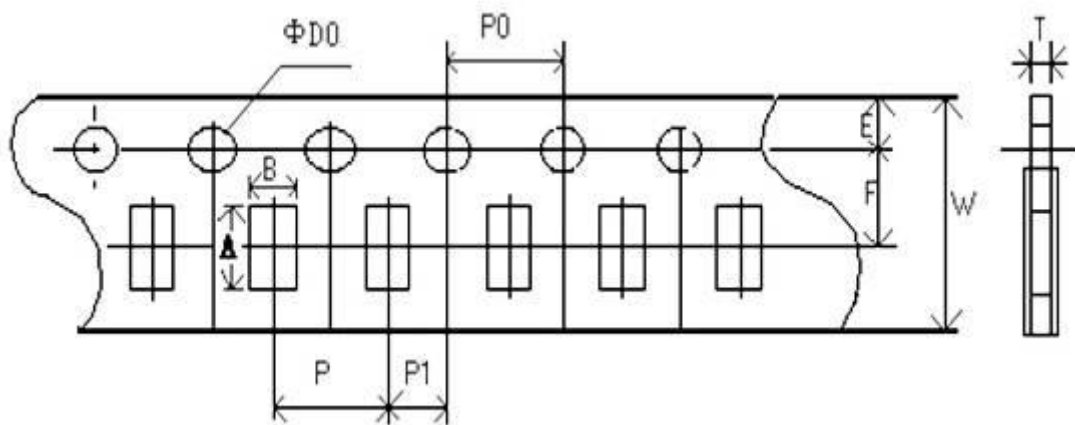

Type	A(mm)	B(mm)	W(mm)	E(mm)	F(mm)
S0603-F	1.85±0.10	1.10±0.10	8.00±0.20	1.75±0.10	3.50±0.05
Type	P(mm)	P0(mm)	P1(mm)	D0(mm)	T(mm)
S0603-F	4.00±0.10	4.00±0.10	2.00±0.05	1.50±0.10	0.60±0.10

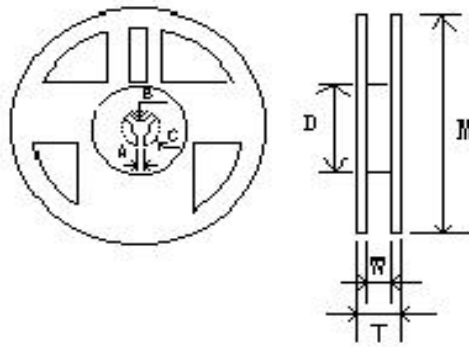

Type	M(mm)	W(mm)	T(mm)	A(mm)	B(mm)	C(mm)	D(mm)
S0603-F	178.00±2.00	9.50±1.00	12.50±1.50	2.00±0.50	13.00±0.50	21.00±0.50	58.00±2.00

Storage

- The ambient temperature recommended for storage shall be between 5°C~30°C
- The relative humidity recommended for storage shall be between 25%RH~60%RH
- Sealed plastic bags with desiccant shall be used to reduce the oxidation of the termination and shall only be opened prior to use
- The products shall not be stored in areas where harmful gases containing sulfur or chlorine are present