



General

- Chip size from 2512 to 5931
- Resistance value from 0.2mΩ to 5mΩ
- Low thermal EMF.
- Low TCR.
- Lead free, RoHS compliant for global.
- Applications and halogen free.

Application

- Switching model power supply.
- Battery pack.
- Notebook, personal computer.
- Test Instrument.
- Power Amplifier.

Electrical Specifications

Type	Power Rating at 70°C(W)	Resistance Range (mΩ)	Material	TCR (ppm/°C)	Resistance tolerance	Operation Temp. Range
2512	3	1	MnCu	±150	±0.5%(D) ±1%(F) ±2%(G) ±5%(J)	-55°C~+170°C
		2	FeCr	±75		
3921	5	0.2、0.3、0.5、1	MnCu	±150		
		1、	Karma	±75		
		1、2、3、4、5	FeCr			
5931	7	0.2、0.3、0.5	MnCu	±150		
		1、2、3	FeCr	±75		

Part Number information

SMS 39 F 5 F R002 T

【1】 【2】 【3】 【4】 【5】 【6】 【7】

- 【1】 Series Name: SART Shunt Type
 【2】 Chip size: 25:2512 39:3921 59:5931
 【3】 Material Code: M:MnCu F:FeCr K:Karma
 【4】 Power Code: 3:3W 5:5W 7:7W
 【5】 Resistance Tolerance: D:±0.5% F:±1% G:±2% J:±5%
 【6】 Resistance Code: 0L20=0.2mΩ R002=2mΩ
 【7】 Packaging Code: T:Tape& Reel B:Bulk Pack

Dimensions



By laser trimming (Front view)



By laser trimming (Back view)

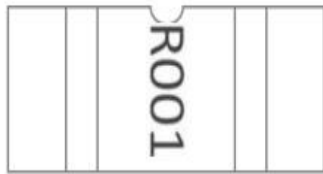

By mechanical trimming (Front view)

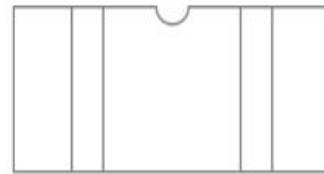

By mechanical trimming (Back view)

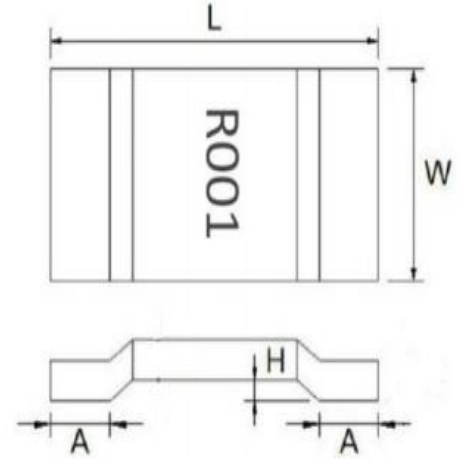

Type	Resistance (mΩ)	L (mm)	W (mm)	A (mm)	H (mm)
2512	1、 2	6.40±0.20	3.30±0.25	1.20±0.20	0.50±0.10
3921	0.2	10.00±0.30	5.20±0.30	2.00±0.30	0.50±0.10
	0.3				
	0.5				
	1				
	2				
	3				
5931	0.2	15.00±0.30	7.70±0.30	4.20±0.30	0.50±0.10
	0.3				
	0.5				
	1				
	2				
	3				

Recommended Land Patterns

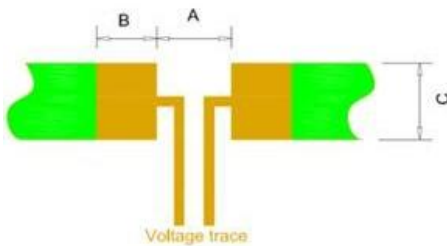

Type	A (mm)	B (mm)	C (mm)
2512	3.6	2.35	3.7
3921	5.60	2.70	6.20
5931	5.60	5.20	8.75

Materials

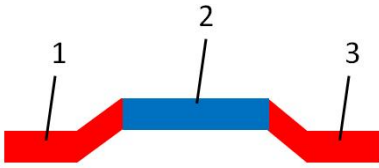

No.	Materials
1	Copper electrode
2	MnCu/FeCr/Karma
3	Copper electrode

Power Derating Curve

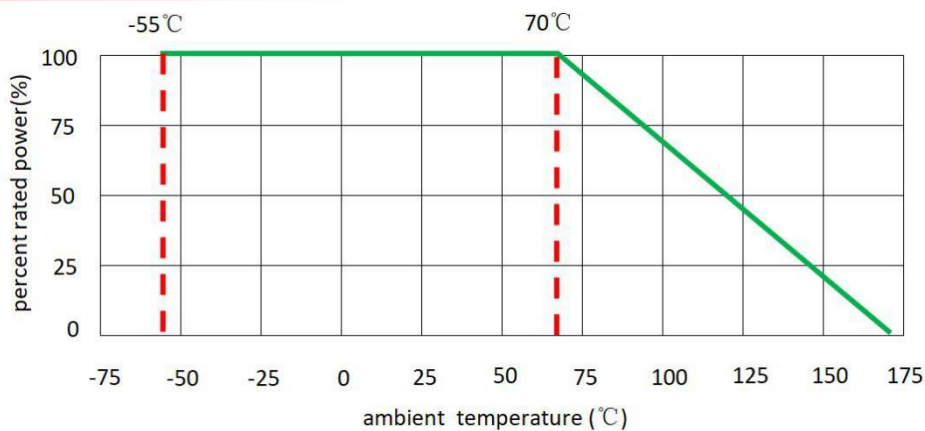

Recommended Solder Curve

1. Infrared Reflow

- Temperature: 260°C
- Time: 5sec Max.
- Recommend Reflow profile:

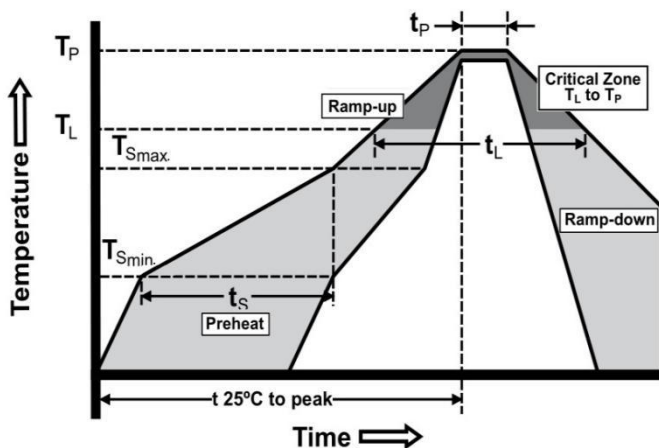

Profile Feature	Pb-Free Assembly
Average Ramp-up Rate (T _{Smax} to T _p)	3°C/sec Max.
Preheat Temperature Min.(T _{Smin}) Temperature Max.(T _{Smax}) Time(T _{Smin} to T _{Smax})(t _s)	150°C 200°C 60sec~120sec
Peak Temperature(T _p)	260°C
Time(tp) within 5°C of actual Peak Temperature(T _p)	5sec
Melting tin time(t _L)	20sec~30sec
Ramp-down Rate	6°C/sec Max.
Time 25°C to peak Temperature	8 min Max.

2. Hand Soldering

- Temperature: 350°C
- Time: 5sec Max

Product Characteristics

Item	Test condition/ Methods	Performance	Standard
Resistance	Measuring resistance value at room temperature 25°C±5°C	Refer to SART Spec	IEC60115-1 4.5
Temperature coefficient of resistance	$TCR = \frac{R-R_0}{R_0} \frac{(T_2-T_1)}{T_1 T_2} \times 10^6$ Test temperature: +25°C~+125°C	Refer to SART Spec	MIL-STD-202 Method 304
Short time Overload	5 times the rated power for 5 seconds	$ \Delta R \leq \pm 1\%$	IEC 60115-1 4.13
Resistance to Soldering Heat	260°C± 5°C time: 10sec± 0.5sec	$ \Delta R \leq \pm 1\%$	MIL-STD-202 Method 210
Thermal shock	-55°C (15min)/+150°C(15min), 1000 cycles	$ \Delta R \leq \pm 1\%$	MIL-STD-202 Method107G
Low temperature operation	Rating power at -65°C for 45 min	$ \Delta R \leq \pm 1\%$	MIL-STD-26E
High Temperature Storage	170°C for 1000hours, No power	$ \Delta R \leq \pm 1\%$	IEC6011501-4.25
Temperature Humidity Bias Test	+85°C, 85% RH, 10%bias, 1000hours	$ \Delta R \leq \pm 0.5\%$	MIL-STD-202 Method103
Mechanical shock	100 g's ,6 msec, 5pulses	$ \Delta R \leq \pm 0.5\%$	MIL-STD-202 Method 213
Vibration	The frequency varies from 10HZ to 2000HZ, 1 min, 3 directions, and 12 hours	$ \Delta R \leq \pm 0.5\%$	MIL-STD-202 Method 204
Load life	70°C± 2°C, 1000 hours, at rated power 1.5 hours "ON", 0.5 hours "OFF"	$ \Delta R \leq \pm 1\%$	MIL-STD-202 Method 108
Moisture resistance	MIL-STD-202,method 106, No power, 7b not required	$ \Delta R \leq \pm 1\%$	MIL-STD-202 Method 106

Packaging

1. Embossed Tape Dimensions

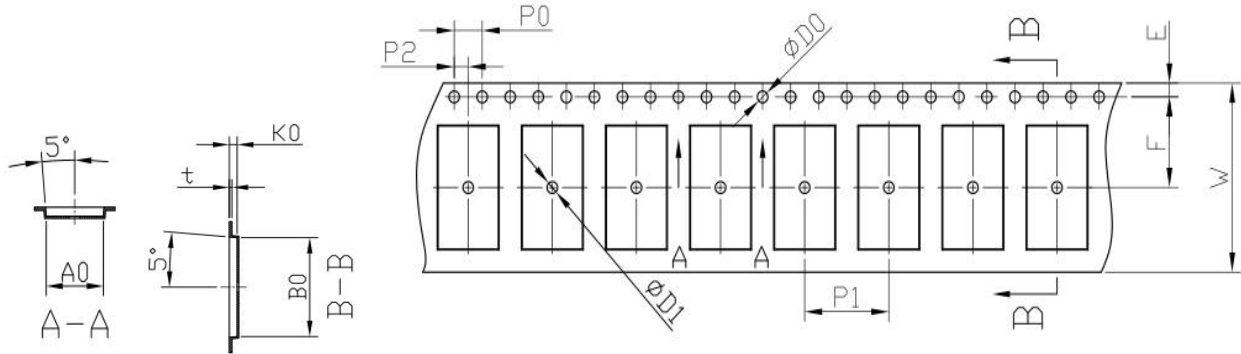

Type	A (mm)	B (mm)	E (mm)	F (mm)	W (mm)	t (mm)
3921	6.00±0.20	10.60±0.20	1.75±0.10	11.50±0.10	24.00±0.30	0.40±0.05
5931	8.60±0.20	15.60±0.20	1.75±0.10	11.50±0.10	24.00±0.30	0.40±0.05
Type	P0 (mm)	P1 (mm)	P2 (mm)	D0 (mm)	D1 (mm)	K0 (mm)
3921	4.00±0.10	8.00±0.10	2.00±0.05	1.50±0.10	1.50±0.10	1.20±0.10/2.50±0.10
5931	4.00±0.10	12.00±0.10	2.00±0.05	1.50±0.10	1.50±0.10	1.20±0.10/2.35±0.10

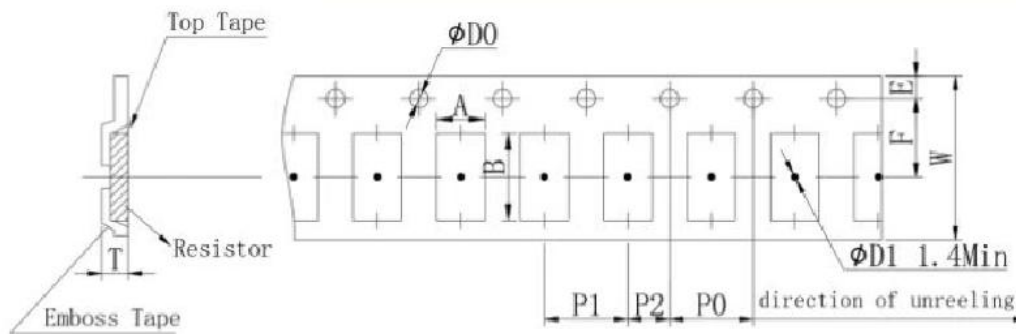

Type	A (mm)	B (mm)	W (mm)	E (mm)	F (mm)
2512	3.50±0.20	6.80±0.20	16.00±0.30	1.75±0.10	7.5±0.10
Type	P0 (mm)	P1 (mm)	P2 (mm)	D0 (mm)	T (mm)
2512	4.0±0.10	8.00±0.10	2.00±0.05	1.50±0.10	1.80±0.10

2. Reel Dimensions

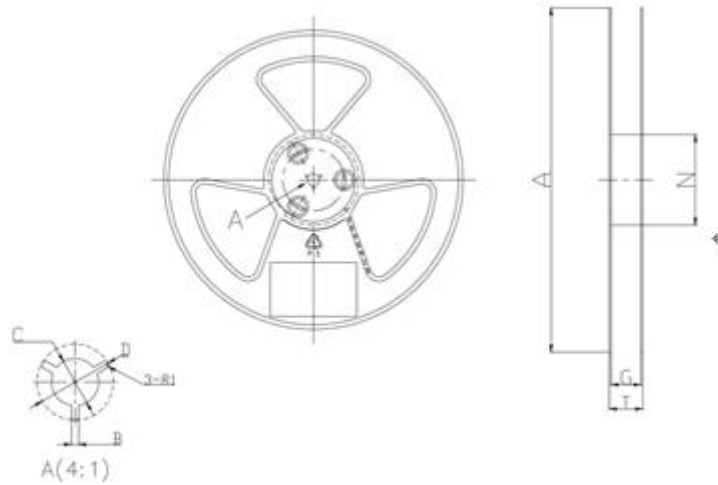

Type	A (mm)	N (mm)	C (mm)	D (mm)	B (mm)	G (mm)	T (mm)
3921	330.0±2.0	100.0±1.5	13.0±0.5	21.0±0.5	2.3±0.5	24.5±1.5	28.5±2.0
5931	330.0±2.0	100.0±1.5	13.0±0.5	21.0±0.5	2.3±0.5	24.5±1.5	28.5±2.0

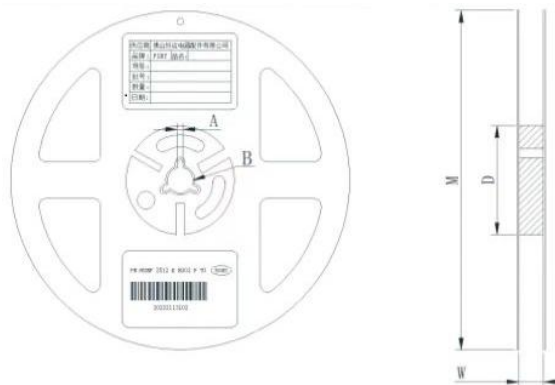

Type	W (mm)	M (mm)	A (mm)	B (mm)	D (mm)
2512	17.0±0.5	330.0±2.0	2.0±0.5	13.5±0.5	60.0±1.0

3. Quantity of Package

Type	Resistance (mΩ)	Quantity (pcs)
2512	1、 2	4000
3921	2、 3、 4、 5	2500
	0.2、 0.3、 0.5、 1	1500
5931	0.5、 2、 3	2000
	0.2、 0.3、 1	1000

4. Peeling Test

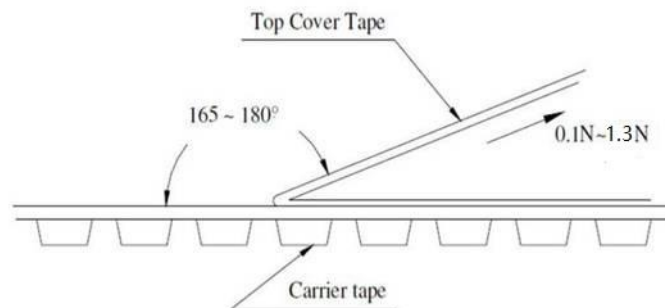

Storage

- The ambient temperature shall be between 5°C~30°C.
- The relative humidity recommended for storage is between 25%RH~60%RH.
- Sealed plastic bags with desiccant shall be used to reduce the oxidation of the termination and shall only be opened prior to use.
- The products shall not be stored in areas where harmful gases containing sulfur or chlorine are present.