





General

- Fast acting, Inrush withstand capability
- Wire-In-Air performance
- Wide range of current rating available
- 6.1mm× 2.5mm square shape surface mount
- Higher temperature profiles
- -55°C~125°C operating temperature
- Excellent environmental integrity
- RoHS compliant
- Halogen-free

Agency / Certificate Information

Agency	File Number	Ampere Range
	E319512	1A~60A
	PSE18021410	1A~5A
	PSE18021408	6.3A~10A
	CQC11012056270	1A~10A

Application

- Battery pack
- Storage system
- Power supply
- PC & PC peripherals
- Game console
- PC server
- Cooling fan system
- Wireless basestation
- Industrial equipment
- Telecom system
- LCD monitor and modules
- Medical equipment

Electrical Specifications

Part Number	Current Rating (A)	Voltage Rating (V)	Interrupting Rating (V)	Typical Cold DCR* (mΩ)	Typical I ² T** (A ² sec)	
S6125-F-1.0A	1	125	UL: 50A 125V AC 50A 160V DC	80.0	0.56	
S6125-F-1.25A	1.25	125		CQC/PSE: 100A 100V AC	60.0	0.84
S6125-F-1.6A	1.6	125			38.0	1.23
S6125-F-2.0A	2	125			30.0	1.34
S6125-F-2.5A	2.5	125			27.0	1.43
S6125-F-3.0A	3	125		/	22.0	1.88
S6125-F-3.15A	3.15	125		CQC/PSE: 100A 100V AC	21.0	2.05
S6125-F-4.0A	4	125			16.0	3.44
S6125-F-5.0A	5	125			14.0	4.84
S6125-F-6.3A	6.3	125			10.0	10.55
S6125-F-7.0A	7	125			9.4	10.58
S6125-F-8.0A	8	125			7.4	17.62
S6125-F-10.0A	10	125			5.9	30.30
S6125-F-12.0A	12	65		200A 86V DC	4.8	42.22
S6125-F-15.0A	15	65		UL: 50A 65V AC 50A 65V DC	3.7	69.75
S6125-F-20.0A	20	65			3	132.04
S6125-F-30A@L	30	72	UL: 200A86V DC & 150A 72V DC	1.4	390	
S6125-F-30A@H	30	65	UL: 200A86V DC & 500A 65V DC	1.3	540	
S6125-F-40A	40	63	UL: 500A 63V DC	1.10	960	
S6125-F-50A	50	63		0.95	1305	
S6125-F-60A	60	63		0.80	1969	

* Measured at ≤10% rated current and 25°C

** Melting I²T at 10 times of rated current

Part Number Information

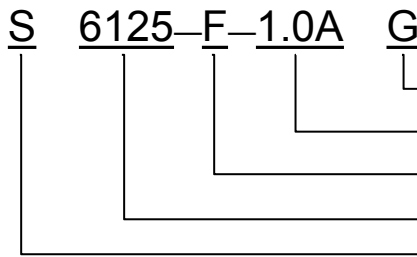

“G” or “blank”: G=Ag Plated Brass Cap, blank=Au Plated Brass Cap
“1.0A” Ampere Rating: 1A
“F” Electrical Characteristic: F = Fast acting
“6125” Size Number
“S” Symbol of SART

Dimensions

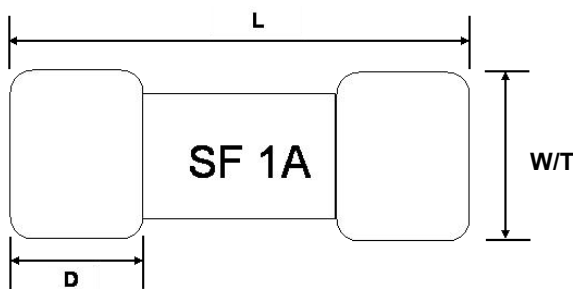

Type	L (mm)	W/ T (mm)	D (mm)
S6125-F	6.10±0.20	2.50±0.10	1.40±0.10

Recommended Land Patterns

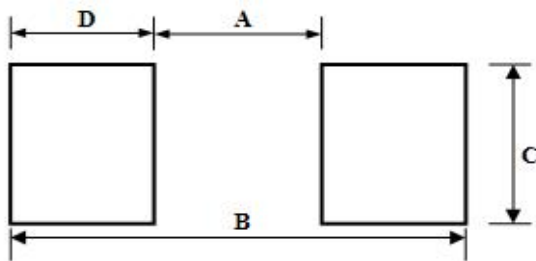

Materials

Components	Material
Body	Ceramic
Terminations	Au Plated Brass Cap or Ag Plated Brass Cap
Element	Nickel alloy or Copper Alloy

Type	A(mm)	B(mm)	C(mm)	D(mm)
S6125-F	3.00±0.30	8.00±0.30	3.00±0.30	2.50±0.30

Dimensions of Standard Test Board

Type	Ampere Rating	Board Thickness (mm)	Copper Layer Thickness (mm)	Copper Trace Width (mm)
S6125-F	1A~6.3A	1.6	0.035	5
	7A~10A	1.6	0.070	7.5
	12A~20A	1.6	0.080	10
	30A@L 30A@H	1.6	0.175	10
	40A~60A	1.6	0.175	33

Time Current Curve

I²T VS Time Curve

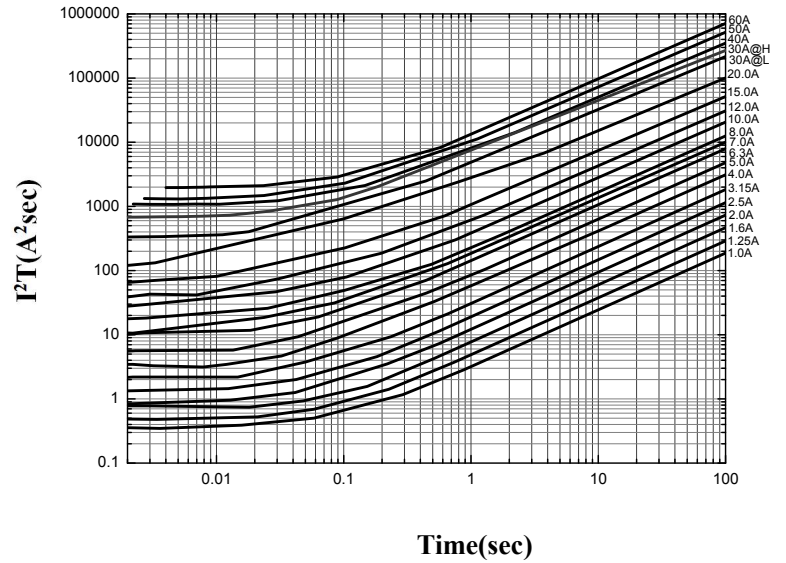
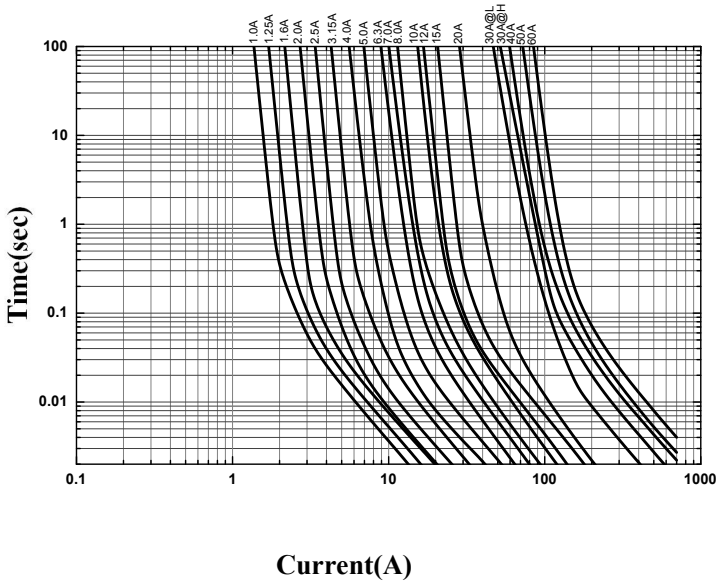

Electrical Characteristics

Type	Ampere Rating	% of Current Rating	Opening Time
S6125-F	1A~60A	100	4hours Min.
	1A~10A	200	5sec Max.
	1A~10A	125	1hour Min.
	12A~20A	200	20sec Max.
	30A@L	250	10sec Max.
	30A@H	350	1sec Max.
	30A@L、40A~60A	200	60sec Max.

Temperature Derating Curve

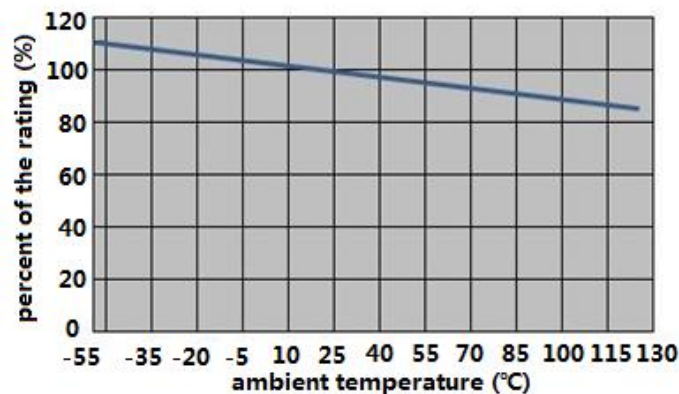

Product Characteristics

Item	Test condition/ Methods	Performance	Standard
Time/Current	100% of current rating	No Fusing, 4hours Min.	UL248-14
	200% of current rating	1A~10A: <5sec 12A~20A: <20sec 30A@L、40A~60A: ≤60sec	SART SPEC
	250% of current rating	30A@L: ≤10sec	SART SPEC
	350% of current rating	30A@H: ≤1sec	SART SPEC
	1000% of current rating	1msec~10msec	IEC60127-4
Voltage Drop	100% of current rating	1A~6.3A: <300mV 7A~10A: <220mV 12A~20A: <150mV 30A~60A: <100mV	IEC-60127-4
Endurance Test	Repeating 100 cycles of 100% of current rating for 1hour "ON", for 15min "OFF", then following by 1hour of 125% of current rating and testing Temperature rise	ΔR : <10% 1A~6.3A: ΔT<75℃ 7A~10A: ΔT <95℃	IEC-60127-4
	100% of current rating for 4hours, then testing Temperature rise	ΔR : <10% 12A~60A: ΔT <105℃	UL248-14
Interrupting Ability	1A~10A: 50A 125V AC&50A 160V DC&100A 100V AC 12A~20A: 50A 65VAC&50A 65VDC&200A 86V DC 30A@L: 200A86V DC & 150A 72V DC 30A@H: 200A86V DC & 500A 65V DC 40A~60A: 500A 63V DC	without permanent arcing, ignition and bursting of fuse link	UL248-14 IEC60127-4
Solderability	240℃±5℃, 3sec±0.5sec	95% coverage Min.	IEC60127-4 IEC60068-2-20; MIL-STD-202
Resistance to Soldering	260℃±5℃, 10sec±0.5sec	ΔR : <10%	MIL-STD-202 Method 210
High Temperature Operating Life	T=70℃±2℃, 60% of current rating, 96 hours	ΔR : <10%	MIL-STD-202 Method 108
Humidity (Steady State)	T=40℃±2℃, RH=90%~95%, 1000 hours	ΔR : <10%	MIL-STD-202 Method 103
Low Temperature Storage	T=-55℃±3℃, 96 hours	ΔR : <10%	IEC60068-2-1
High Temperature Storage	T=125℃±2℃, 96 hours	ΔR : <10%	IEC60068-2-2
Salt Spray	5% salt solution, 48 hours	ΔR : <10%	MIL-STD-202 Method 101
Thermal Shock	100 cycles, -65℃ to +125℃, 30 minutes@each extreme	ΔR : <(10%R+0.005Ω)	IEC 60068-2-14

Recommended Solder Curve

1. Infrared Reflow:

- Temperature: 260°C
- Time: 20sec Max.
- Recommend Reflow profile

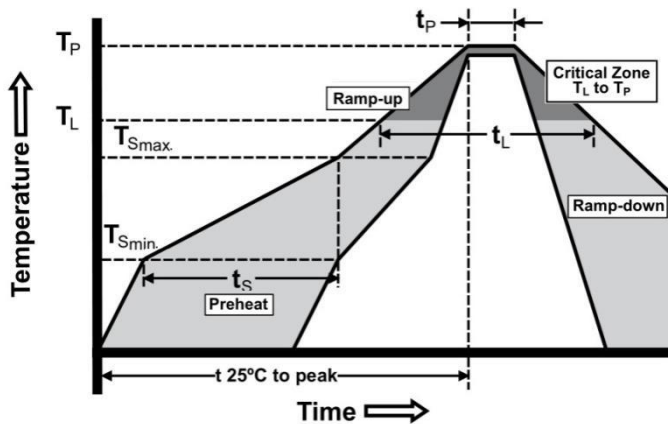

Profile Feature	Pb-Free Assembly
Average Ramp-up Rate(T_{Smax} to T_P)	3°C/sec Max.
Preheat Temperature Min. (T_{Smin}) Temperature Max. (T_{Smax}) Time (T_{Smin} to T_{Smax})	150°C 200°C 60sec~120sec
Peak Temperature (T_P)	260°C
Time within 5°C of actual Peak Temperature (t_P)	20sec
Temperature (T_L)	217°C
Melting tin time (t_L)	60sec~150sec
Ramp-down Rate	6°C/sec Max.
Time 25°C to peak Temperature	8min Max.

Packaging

- 1000 pieces of fuses in emboss taper and reeled on a 178mm(7 inch) reel.

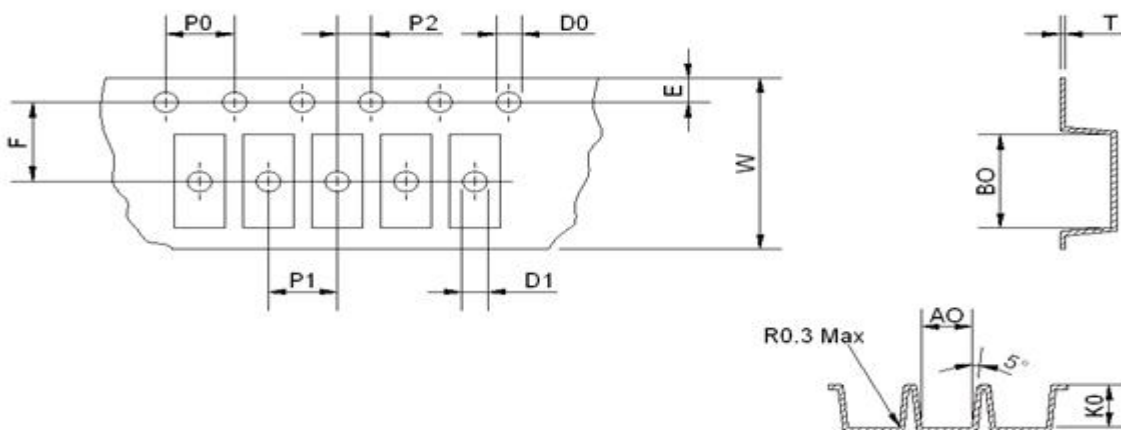

Type	A0(mm)	B0(mm)	K0(mm)	P0(mm)	P1(mm)	P2(mm)
S6125-F	2.70±0.10	6.40±0.10	2.70±0.10	4.00±0.10	4.00±0.10	2.00±0.10
Type	E(mm)	F(mm)	D0(mm)	D1(mm)	W(mm)	T(mm)
S6125-F	1.75±0.10	5.50±0.10	1.50±0.10	1.50±0.25	12.00±0.15	0.25±0.05

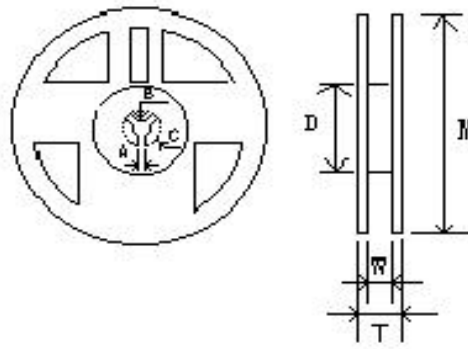

Type	M(mm)	W(mm)	T(mm)	A(mm)	B(mm)	C(mm)	D(mm)
S6125-F	178.00±2.00	12.50±1.00	14.50±1.50	2.00±0.50	13.00±0.50	21.00±0.50	58.00±2.00

Storage

- The ambient temperature recommended for storage shall be between 5°C~30°C.
- The relative humidity recommended for storage shall be between 25%RH~60%RH.
- Sealed plastic bags with desiccant shall be used to reduce the oxidation of the termination and shall only be opened prior to use.
- The products shall not be stored in areas where harmful gases containing sulfur or chlorine are present.