

General

- Chip size from 0603 to 1206
- Resistance value from 1mΩ to 25mΩ
- Low thermal EMF
- Low TCR
- Lead free, RoHS compliant for global
- Applications and halogen free

Application

- Switching model power supply.
- Battery pack.
- Notebook, personal computer.
- Test Instrument.
- Power Amplifier.

Electrical Specifications

Type	Power Rating at 70°C (W)	Resistance Range (mΩ)	TCR (ppm/°C)	Resistance tolerance	Operating Temperature
0603	0.33	1 ≤ R ≤ 4	±100	±1% (F)	-55°C ~ +155°C
		5 ≤ R ≤ 25	±50		
1206	1	1 ≤ R ≤ 4	±100	±1% (F)	
		5 ≤ R ≤ 25	±50	±1% (F) ±0.5% (D)	

Part Number Information

SLT 12 A 1 F R002 I
【1】 【2】 【3】 【4】 【5】 【6】 【7】

【1】 Series Name: SART Long Electrode Four Terminal Metal Foil Type

【2】 Chip size: 06:0603 12: 1206

【3】 Material Code: A:Alloy

【4】 Power Code: D: K:0.33W 1: 1W

【5】 Resistance Tolerance: F: ±1% D: ±0.5%

【6】 Resistance Code: R002 = 2 mΩ R025 = 25 mΩ

【7】 Packaging Code: T:Tape & Reel B: Bulk Pack

Dimensions

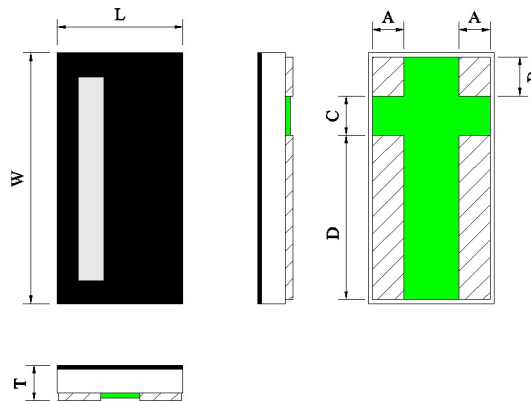

Type	Resistance Range (mΩ)	W (mm)	L (mm)	A (mm)	B (mm)	C (mm)	D (mm)	T (mm)
0603	1~25	1.60±0.20	0.80±0.15	0.18±0.10	0.23±0.10	0.40±0.10	0.93±0.20	0.55±0.10
1206	1~25	3.20±0.20	1.55±0.20	0.41±0.20	0.46±0.20	0.50±0.20	2.16±0.20	0.50±0.20

Recommended Land Patterns

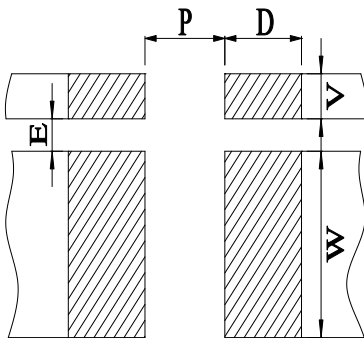

Type	Resistance Range (mΩ)	P (mm)	W (mm)	D (mm)	V (mm)	E (mm)
0603	1~25	0.35	1.30	0.40	0.40	0.20
1206	1~25	0.762	2.29	1.014	0.762	0.381

Materials

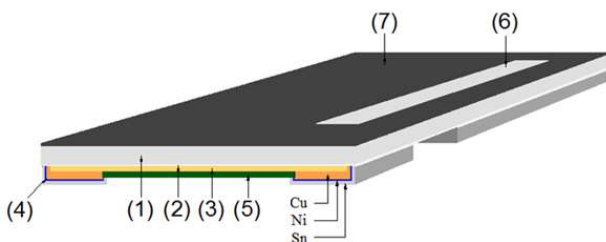

No.	Materials	No.	Materials
1	Alumina Ceramic	5	Protective coating
2	Epoxy	6	Marking coating
3	Cu - alloy	7	Marking coating
4	Terminal electrode	/	/

Temperature Derating Curve

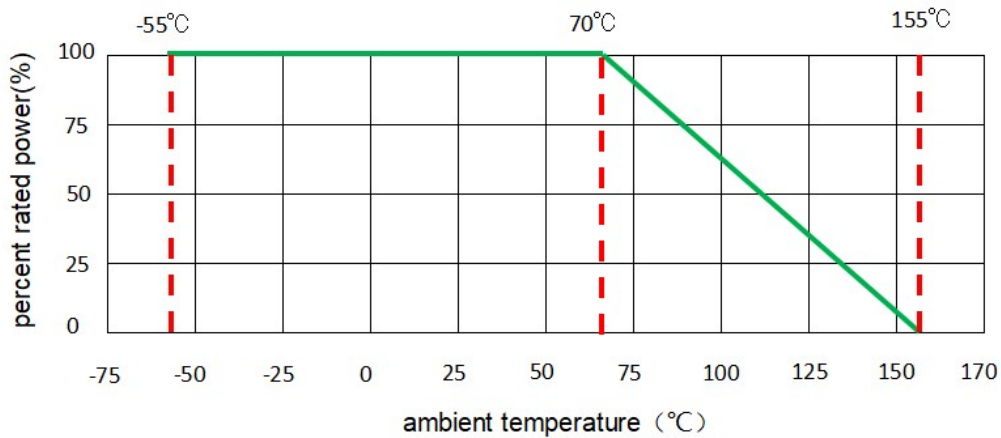

Recommended Solder Curve

- Infrared Reflow
 - Temperature: 260°C
 - Time: 5sec Max.
 - Recommend Reflow profile:

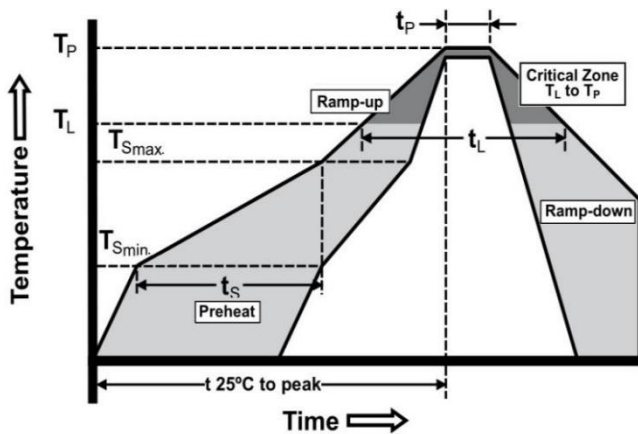

Profile Feature	Pb-Free Assembly
Average Ramp-up Rate (TSmax to TP)	3°C/sec Max.
Preheat Temperature Min. (TSmin) Temperature Max. (TSmax) Time (TSmin to TSmax)	150°C 200°C 60sec~120sec
Peak Temperature (TP)	260°C
Time within 5°C of actual Peak Temperature (TP)	5sec
Melting tin time (TL)	20sec~30sec
Ramp-down Rate	6°C/sec Max.
Time 25°C to peak Temperature	8min Max.

- Wave soldering
 - Reservoir Temperature: 260°C
 - Time in Reservoir: 10sec Max.

- Hand Soldering
 - Temperature: 350°C
 - Time: 5sec Max.

Product Characteristics

Item	Test condition/ Methods	Performance	Standard
Resistance	Measuring resistance value at room temperature 25°C ±5°C	Refer to SART Spec	IEC60115-1 4.5
Temperature Coefficient of Resistance	$TCR = \frac{R-R_0}{R_0(T_2-T_1)} \times 10^6$ Test temperature: +25°C~+125°C	Refer to SART Spec	IEC60115-1 4.8
Short time Overload	2.5 times the rated power for 5 sec	\Delta R ≤ 1.0%	IEC 60115-1 4.13
Solderability	245°C ±5°C for 3 sec ±1 sec	Min 95% coverage	IEC 60115-1 4.17
Resistance to Soldering Heat	260°C ± 5°C, time: 10 sec ±1 sec	\Delta R ≤ 1.0%	IEC 60115-1 4.18
Thermal Shock	-55°C ± 3°C (30min) / +125°C ± 3°C (30min), 1000 cycles	\Delta R ≤ 1.0%	IEC 60115-1 4.19
Damp Heat Steady State	40°C ± 2°C, 90%~95%RH, 1000 hours	\Delta R ≤ 1.0%	IEC 60115-1 4.24
Load Life at 70°C	70°C ± 2°C, V _{test} = V _{max} , 1.5 hours "ON", 0.5 hours "OFF", 1000 hours	\Delta R ≤ 1.0%	IEC 60115-1 4.25.1
High Temp. Exposure	125°C ± 2°C, 1000 hours	\Delta R ≤ 1.0%	IEC 60115-1 4.25.3
Bending test	Epoxy thickness 1.6mm, Fulcrums distance 90mm, Bending distance : 2mm	\Delta R ≤ 1.0%	IEC 60115-1 4.33
Mechanical Shock	a = 50g's, t = 11ms	\Delta R ≤ 1.0%	IEC 60115-1 4.21

Packaging

1. Paper Tape Dimensions

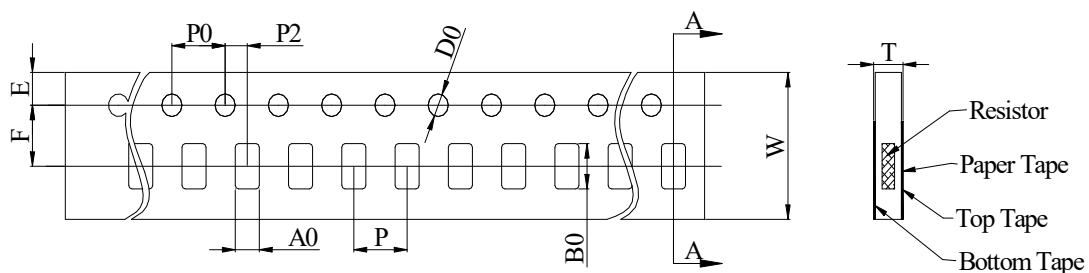

Type	W (mm)	P0 (mm)	P (mm)	P2 (mm)	A0 (mm)
0603	8.00±0.30	4.00±0.10	4.00±0.10	2.00±0.10	0.98±0.20
Type	B0 (mm)	D0 (mm)	F (mm)	E (mm)	T (mm)
0603	1.85±0.20	1.50±0.10	3.50±0.10	1.75±0.10	0.75±0.20

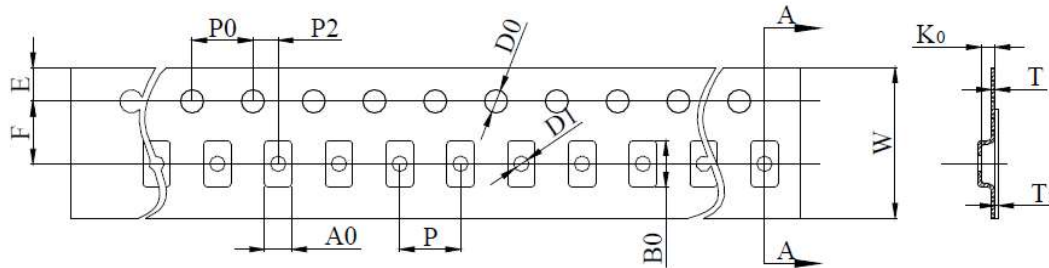

Type	W (mm)	P0 (mm)	P (mm)	P2 (mm)	A0 (mm)	B0 (mm)
1206	8.00±0.30	4.00±0.10	4.00±0.10	2.00±0.10	1.90±0.20	3.50±0.20
Type	D0 (mm)	F (mm)	E (mm)	T (mm)	T1 (mm)	K0 (mm)
1206	1.50±0.10	3.50±0.10	1.75±0.10	0.20±0.10	Max.0.1	0.85±0.20

2. Reel Dimensions

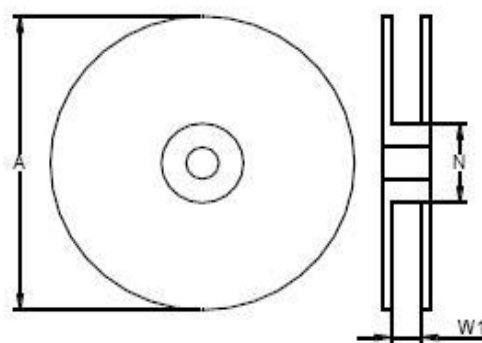

Type	A (mm)	N (mm)	W1 (mm)
0603 1206	178.00±5.00	60.00±2.00	9.00±1.00

3.Quantity of Package

Type	Quantities (PCS)
0603/1206	5000

Peeling Test

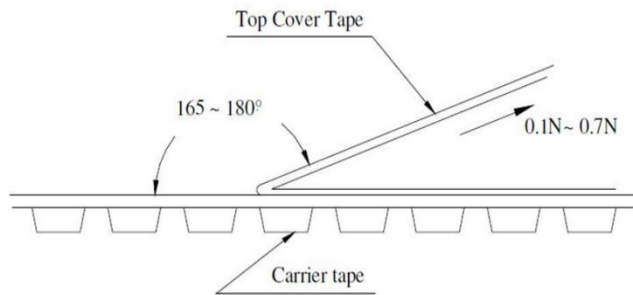

Storage

- The ambient temperature shall be between 5°C~30°C.
- The relative humidity recommended for storage is between 25%RH~60%RH.
- Sealed plastic bags with desiccant shall be used to reduce the oxidation of the termination and shall only be opened prior to use. The products shall not be stored in areas where harmful gases containing sulfur or chlorine are present.